

# ML4062-MCB-TR

## Technical Reference

**QSFP-DD MCB**  
MSA Compliant

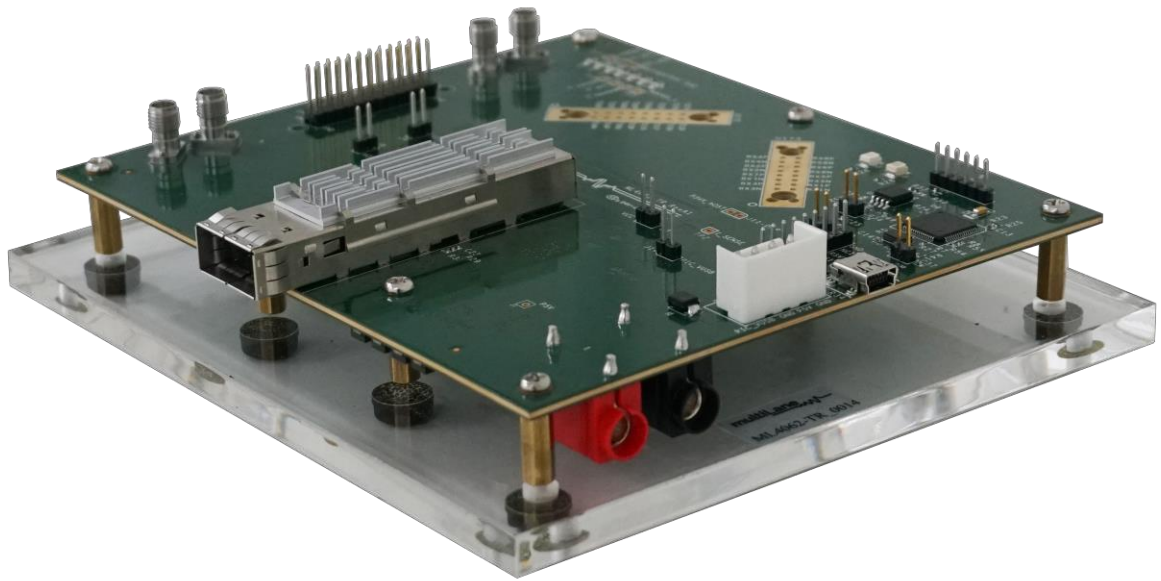

## Table of Contents

<b>1</b>	<b>Overview .....</b>	<b>3</b>
1.1	ML4062-MCB-TR QSFP-DD   Key Features .....	3
<b>2</b>	<b>ML4062-MCB-TR Hardware .....</b>	<b>3</b>
2.1	Power-Up .....	3
2.2	Operating Conditions .....	4
2.3	LED Indicators .....	4
2.4	Low Speed Signals .....	5
2.4.1	External I2C .....	5
2.4.2	External HW Control .....	5
2.4.3	QDD Connector Pins Access .....	6
<b>3</b>	<b>ML4062-MCB-TR Software .....</b>	<b>6</b>
3.1	USB Driver .....	7
3.2	GUI .....	7
<b>4</b>	<b>Hardware Revision .....</b>	<b>7</b>
<b>5</b>	<b>Firmware Revision .....</b>	<b>7</b>
<b>6</b>	<b>Bootloader .....</b>	<b>7</b>

## Table of Figures

Figure 1:	On-board LEDs .....	4
Figure 2:	External I2C .....	5
Figure 3:	External Control Signals .....	5
Figure 4:	Low Speed Signals Schematics .....	6
Figure 5:	QDD Connector Pins Access .....	6

## 1 Overview

The **ML4062-MCB-TR** is designed to provide an efficient and easy method of programming and testing 400G QSFP-DD transceivers and active optical cables. It includes a complete user-friendly GUI supporting all features defined by QSFP-DD MSA and simplifying configuration processes to enable intuitive memory map programming and testing. It is designed to simulate an ideal environment for QSFP-DD transceivers module testing, characterization and manufacturing.

### 1.1 ML4062-MCB-TR QSFP-DD | Key Features

- Supports 8x50G interfaces
- High performance signal integrity traces from TR40 connectors to QSFP-DD connector
- All 8 channels have matching trace length
- I2C master driven from both on board microcontroller or external pin headers
- On-board LEDs display MSA signals states
- On-board pin headers for MSA input control signals
- User friendly GUI for I2C R/W commands and loading custom MSA memory maps
- Controllable module voltage: 3.15 V, 3.3 V and 3.45 V
- Current Sense
- Voltage sense
- Temperature sense
- Four corner testing capability
- USB interface

## 2 ML4062-MCB-TR Hardware

The subsequent sections cover the essential parts in the hardware, for board operation and testing.

### 2.1 Power-Up

To power up the **ML4062-MCB-TR** host, steps are as follow:

- The host TOP is where the cage is mounted
- Two options are available to power up the board:
  - Using the four pins power connector (J2) that should be connected to 5 V AND 3.3 V taking into account pins distribution, where the SMD jumper (U11) must be populated
  - Using the banana plug (U6) that should be connected to 3.3 V where the SMD jumper (U12) must be populated
- Connect the host to your PC using a Type-B mini to Type-A USB cable.

## 2.2 Operating Conditions

According to the powering method described in section 3.1, the input voltage supply must follow the table below.

Parameter	Symbol	Condition	Min	Typical	Max	Unit
+5	P5V	Supply from J2 (P5V pin)	-	5	-	V
+3.3	PIC_VUSB	Supply from J2 (P3V3 Pin) OR banana plug U6	3.0	3.3	3.6	

Table 1: Voltage Operating Conditions

## 2.3 LED Indicators

The **ML4062-MCB-TR** includes on-board LEDs, for quick debugging and monitoring purposes. LEDs are summarized below:

- LED D11 indicates whether a USB cable is plugged or not.
- LEDs D9 and D10, colored green and red, respectively, are used for diagnostic purposes:
  - If D9 is on: USB is locked and device is recognized by the USB driver
  - If D10 is on: USB is not connected or USB driver is not found
  - If both are off: board is not powered correctly or firmware is corrupted
  - If both are blinking: the board is in Bootloader mode
- Led D1: LPMODE signal monitoring
- LED D4: RESET\_L signal monitoring
- LED D5: INT\_L signal monitoring
- LED D6: MODPRS\_L signal monitoring
- LED D7: MODSEL\_L

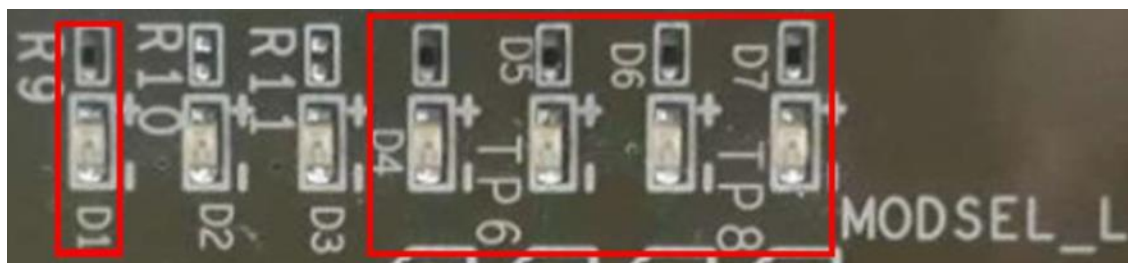

Figure 1: On-board LEDs

## 2.4 Low Speed Signals

### 2.4.1 External I2C

The I2C bus can be accessed externally using U5 pins. In this case a jumper should be placed on pin header P2 (HW\_I2C) shown in the image below.

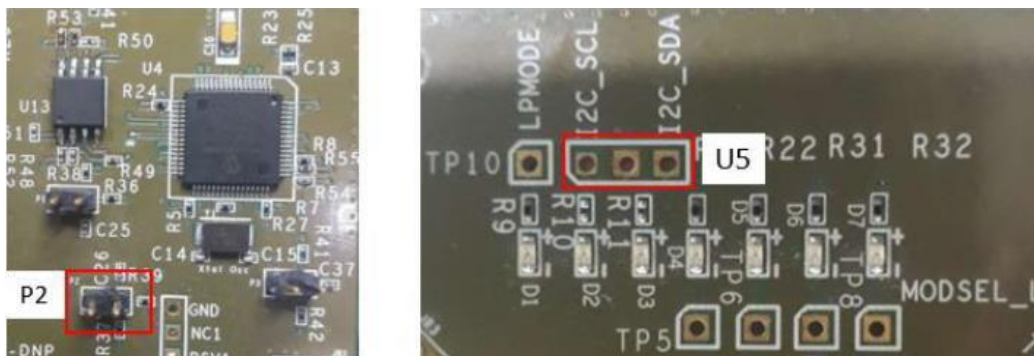

Figure 2: External I2C

### 2.4.2 External HW Control

Also, Low Speed Signals are controllable using an external source, this can be done through (J18) pin headers. In this case a jumper should be placed on pin header P1(HW\_CTRL) shown in the image below.

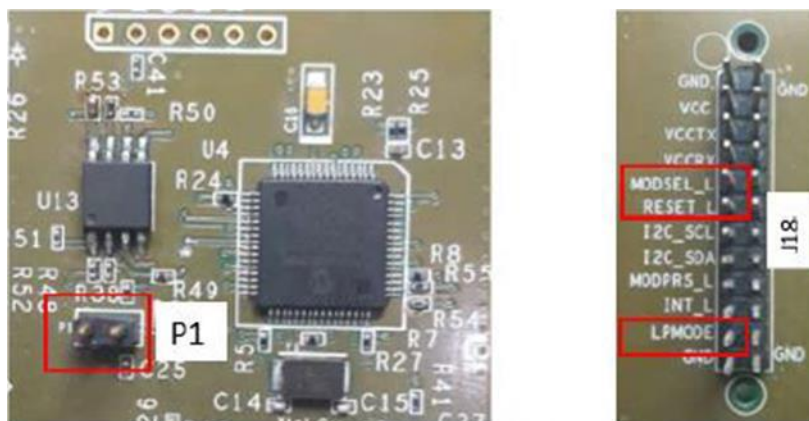

Figure 3: External Control Signals

The low speed signals circuit shown below shows the connection of these signals to the microcontroller and QSPF-DD connector.

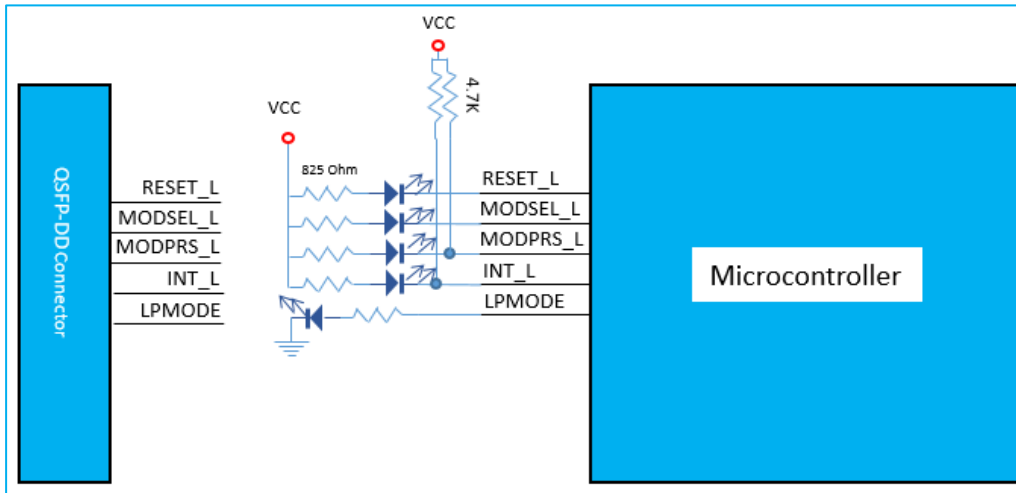

Figure 4: Low Speed Signals Schematics

When the jumper is inserted on P1, the output signals are tri-stated from the microcontroller, and hence could be controlled from an external source.

### 2.4.3 QDD Connector Pins Access

Pin header connectors are available in the **ML4062-MCB-TR**, allowing the access to the QDD connector pins.

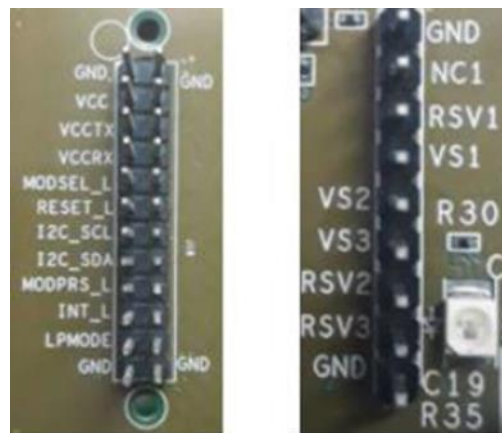

Figure 5: QDD Connector Pins Access

## 3 ML4062-MCB-TR Software

The **ML4062-MCB-TR** is accessible and controlled through application software. This software is MSA compliant and provides a user-friendly interface to operate the board and access all its features. The communication between the **ML4062-MCB-TR** board and the software is established through USB connection.



## 3.1 USB Driver

In order to be able to communicate with the board, user need to install the USB driver of the **ML4062-MCB-TR**. This is available on the website under the following link:

<https://multilaneinc.com/products/ml4062-mcb-tr/>

Below is a brief guide on how to install the USB Driver:

- Power up the board
- Connect the board to the PC through USB cable
- Download the USB driver file
- Go to “Device Manager”
- Find the target device that need to install the driver
- Right-click on the device and select Update Driver Software
- Select Browse my computer for driver software
- Browse you PC and select the driver file
- Click Next and wait until the driver is installed

## 3.2 GUI

For GUI installation and operation, refer to the link below. GUI user manual is available for detailed description.

<https://multilaneinc.com/products/ml4062-mcb-tr/>

## 4 Hardware Revision

- **ML4062-MCB-TR-RevA**: Initial Version

## 5 Firmware Revision

- **ML4062-MCB-TR\_V1\_0**: latest FW **revision**, compatible with the ML4062-MCB-TR RevA hardware.

## 6 Bootloader

Accessing in bootloader mode allows the user to reprogram the microcontroller, this is done as described below:

1. Connect a jumper on (P3) situated close to the microcontroller.
2. Connect a USB cable between the PC and Board.
3. Power up the board with a +3.3 V supply.
4. LEDs (D9, D10) start blinking.
5. Remove jumper.
6. Open the software “Microchip USB HID Bootloader v2.3”.
7. Click on “Open Hex File”.

8. Choose the new FW to download.
9. Click on “Program/Verify”.
10. Once the software finishes programming press on “Reset Device”.
11. After reset the Firmware is successfully updated.



## Revision History

Revision number	Date	Description
0.1	9/3/2020	▪ Initial Version
0.11	11/11/2021	▪ Change Format